

# Reliable®

## Model G VELO Pendent Very Extra Large Orifice Sprinkler

### Low Pressures for High Hazards 0.70" Orifice, 14.0 K, 7psi (0,5 bar) Minimum End - Head Pressure (SIN R4613)

#### Features

The Reliable Model G VELO pendent sprinkler offers opportunity for:

1. Pipe size reduction.
2. Fewer sprinklers.
3. Elimination of booster pumps.
4. The best choice for densities of 0.38 gpm/ft<sup>2</sup> (15 L/min /m<sup>2</sup>) or larger.
5. Simplifies future ESFR conversions.

#### US Patents: 5.890.657 and 5.915.479

#### Listings & Approvals

1. Listed by Underwriters Laboratories, Inc. and Certified by UL for Canada (cULus).
2. Approved by Factory Mutual (FM) as a storage sprinkler.
3. NYC MEA 258-93-E

#### UL Guide Number

VNIV

#### UL Listing Category

Sprinklers, Automatic & Open  
Specific Application Sprinklers

#### Technical Data

Sprinkler Type	Nominal K Factor		Sprinkler Height	Sprinkler Identification Number (SIN)
	US	Metric		
Pendent 0.70 orifice with ¾" NPT (R¾)	14.0	200.0	3.10" (79mm)	R4613

**Note:** This product has been tested and listed for storage applications to qualify its use in lieu of 5.6K or 8.0K Factor sprinklers for the protection of high-piled storage

#### Product Description

The Reliable Model G VELO sprinkler is a Very Extra Large Orifice pendent sprinkler that has been designed to control high challenge fires in both palletized and rack storage occupancies utilizing lower water pressures. The Model G VELO pendent utilizes a center strut solder in compression fusible element.

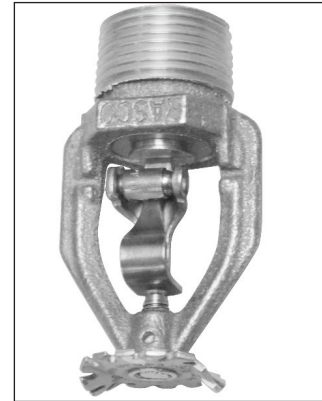

It has been proven in UL and FM full-scale fire testing and complies with all applicable mechanical and hydraulic requirements of the latest sprinkler standards.

This product is intended for use as a standard response standard spray sprinkler in hydraulically designed systems with a minimum pressure of 7 psi (0,5 bar) in accordance with the area/density curves of NFPA 13\*.

#### Design Criteria

The following criteria apply when designing an automatic sprinkler system utilizing the Model G VELO sprinkler for NFPA 13\* applications.

- Sprinkler spacing shall be a minimum of 6 ft. (1.8m).
- Minimum design pressure 7 psi (0,5 bar).
- Factory Mutual (FM) Approval for Model G VELO sprinkler allows installation into drops or branch line fittings.
- Factory Mutual (FM) Loss Prevention Data Sheets contain requirements which differ from NFPA. The Model G VELO is Approved by Factory Mutual installations governed by Data Sheets 8-9 and 2-0.

**Note:** The Model G VELO sprinkler is not a "Large Drop" or "ESFR sprinkler".

#### Temperature Ratings

Classification	Sprinkler Rating		Maximum Ceiling Temperature		Frame Color
	°F	°C	°F	°C	
Ordinary	165	74	100	38	Uncolored White Blue
Intermediate	212	100	150	66	
High	286	141	225	107	

\* For sprinkler standards prior to 1999 edition of NFPA 13 use NFPA standards 231, 231C, 231D & 231F.

## Finishes

Standard Finishes <sup>(1)</sup>	Approvals
Natural Bronze <sup>(2)</sup> Bright Chrome Satin Chrome	Approved for all Temperature Ratings
<b>Special Application Finishes*</b>	
Lead Wax Wax/Lead	

<sup>(1)</sup> cULus listed.

<sup>(2)</sup> FM approved for Natural Bronze only.

## Installation

Reliable's Model G VELO Pendant sprinkler must be installed according to the NFPA Standards or the appropriate Factory Mutual Loss Prevention Data Sheet and the Authority Having Jurisdiction.

Installation Approvals	Distance from Deflector to Top of Commodity
Underwriters Laboratories, Inc. (cULus)	36"
Factory Mutual Research (FM)	

\* For sprinkler standards prior to 1999 edition of NFPA 13 use NFPA standards 231, 231C, 231D & 231F.

## Maintenance

Model G VELO Sprinkler should be inspected and the sprinkler system maintained in accordance with NFPA 25. Do not clean sprinklers with soap and water, ammonia or any other cleaning fluids. Remove dust by using a soft brush or gentle vacuuming. Prior to installation, sprinklers should be maintained in the original cartons and packaging until used to minimize the potential for damage to sprinklers that would cause improper operation or non-operation. Remove any sprinkler which has been painted (other than factory applied) or damaged in any way. A stock of spare sprinklers should be maintained to allow quick replacement of damaged or operated sprinklers.

## Model H Sprinkler Wrench

Use only the Model H sprinkler wrench for sprinkler removal and installation. Any other type of wrench may damage the sprinkler.

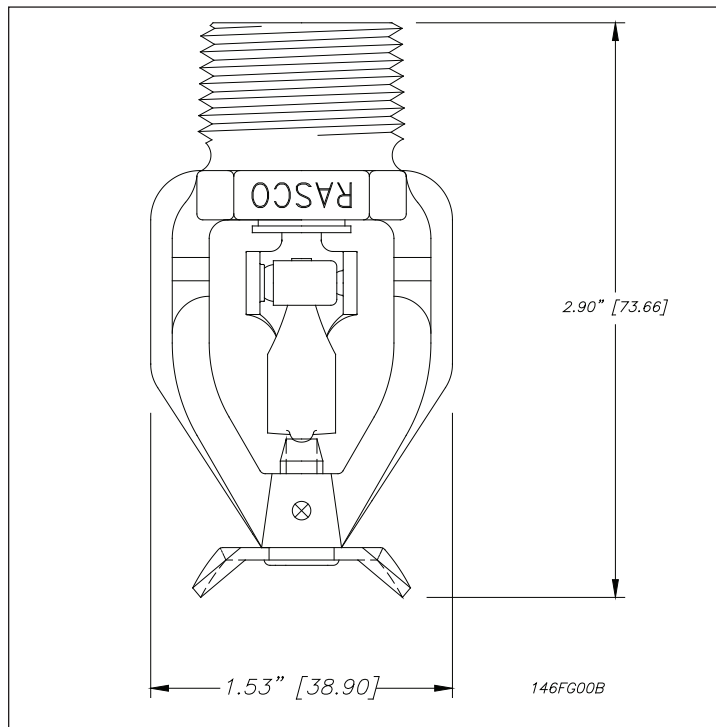

MODEL G VELO PENDENT

The equipment presented in this bulletin is to be installed in accordance with the latest published Standards of the National Fire Protection Association, Factory Mutual Research Corporation, or other similar organizations and also with the provisions of governmental codes or ordinances whenever applicable.

Products manufactured and distributed by Reliable have been protecting life and property for over 90 years, and are installed and serviced by the most highly qualified and reputable sprinkler contractors located throughout the United States, Canada and foreign countries.

Manufactured by



The Reliable Automatic Sprinkler Co., Inc.  
(800) 431-1588 Sales Offices  
(800) 848-6051 Sales Fax  
(914) 829-2042 Corporate Offices  
www.reliablesprinkler.com Internet Address



Revision lines indicate updated or new data.

EG. Printed in U.S.A 11/10 P/N 9999970138